



ISK
BEARINGS

久大轴承有限公司
JOTA BEARING CO., LTD.

JOTA



CF形

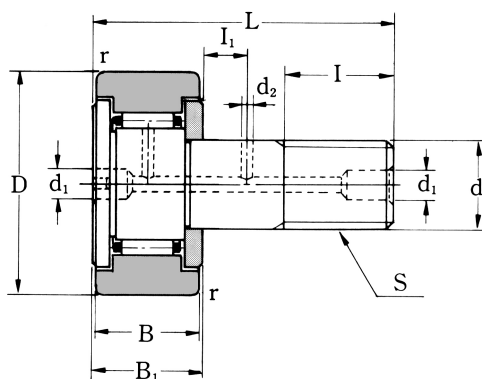
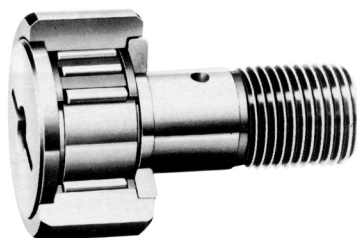

CF

單位：mm

*另有UU型，R型及UUR型

軸承 型號	d	D	S	B	B ₁	L	d ₁	D ₂	I	I ₁	r	靜荷重 C ₀ kgf	動荷重 C kgf	極限 速率 rpm
CF3	3	10	M 3x0.5	7	8	17	-	-	5	-	0.3	72	130	47000
CF4	4	12	M 4x0.7	8	9	20	-	-	6	-	0.5	120	190	37000
CF5	5	13	M 5x0.8	9	10	23	3.1	-	7.5	-	0.5	180	280	29000
CF6	6	16	M 6x1	11	12	28	4	-	9	-	0.5	240	330	25000
CF8	8	19	M 8x1.25	11	12	32	4	-	11	-	0.5	300	390	20000
CF10	10	22	M10x1.25	12	13	36	4	-	13	-	1	370	430	17000
CF10-1	10	26	M10x1.25	12	13	36	4	-	13	-	1	370	430	17000
CF12	12	30	M12x1.5	14	15	40	6	3	14	6	1.5	620	710	14000
CF12-1	12	32	M12x1.5	14	15	40	6	3	14	6	1.5	620	710	14000
CF16	16	35	M16x1.5	18	19.5	52	6	3	18	8	1.5	1090	1040	10000
CF18	18	40	M18x1.5	20	21.5	58	6	3	20	10	1.5	1690	1410	8500
CF20	20	52	M20x1.5	24	25.5	66	8	4	22	12	1.5	2350	1940	7000
CF20-1	20	47	M20x1.5	24	25.5	66	8	4	22	12	1.5	2350	1940	7000
CF24	24	62	M24x1.5	29	30.5	80	8	4	25	12	1.5	3050	2600	6500
CF24-1	24	72	M24x1.5	29	30.5	80	8	4	25	12	1.5	3050	2600	6500
CF30	30	80	M30x1.5	35	37	100	8	4	32	15	2	5350	3470	5000
CF30-1	30	85	M30x1.5	35	37	100	8	4	32	15	2	5350	3470	5000
CF30-2	30	90	M30x1.5	35	37	100	8	4	32	15	2	5350	3470	5000

萬向軸承、端桿軸承

CFH形

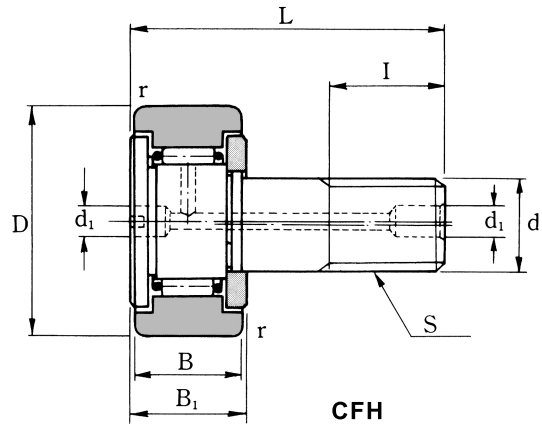
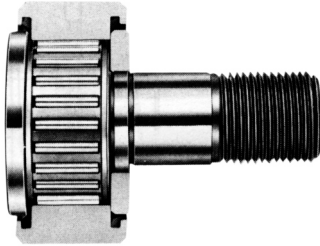

軸徑 mm	軸承型號				主要寸法(mm)			
	圓筒外輪		球面外輪		d	D	S	B
	標準型	UU型	標準型	UU型				
6	CFH 6	CFH 6UU	CFH 6R	CFH 6UUR	6	16	M 6x1	11
8	CFH 8	CFH 8UU	CFH 8R	CFH 8UUR	8	19	M 8x1.25	11
10	CFH 10	CFH 10UU	CFH 10R	CFH 10UUR	10	22	M10x1.25	12
	CFH 10-1	CFH 10-1UU	CFH 10-1R	CFH 10-1UUR	10	26	M10x1.25	12
12	CFH 12	CFH 12UU	CFH 12R	CFH 12UUR	12	30	M12x1.5	14
	CFH 12-1	CFH 12-1UU	CFH 12-1R	CFH 12-1UUR	12	32	M12x1.5	14
16	CFH 16	CFH 16UU	CFH 16R	CFH 16UUR	16	35	M16x1.5	18
18	CFH 18	CFH 18UU	CFH 18R	CFH 18UUR	18	40	M18x1.5	20
20	CFH 20	CFH 20UU	CFH 20R	CFH 20UUR	20	52	M20x1.5	24
	CFH 20-1	CFH 20-1UU	CFH 20-1R	CFH 20-1UUR	20	47	M20x1.5	24
24	CFH 24	CFH 24UU	CFH 24R	CFH 24UUR	24	62	M24x1.5	29
	CFH 24-1	CFH 24-1UU	CFH 24-1R	CFH 24-1UUR	24	72	M24x1.5	29
30	CFH 30	CFH 30UU	CFH 30R	CFH 30UUR	30	80	M30x1.5	35
	CFH 30-1	CFH 30-1UU	CFH 30-1R	CFH 30-1UUR	30	85	M30x1.5	35
	CFH 30-2	CFH 30-2UU	CFH 30-2R	CFH 30-2UUR	30	90	M30x1.5	35

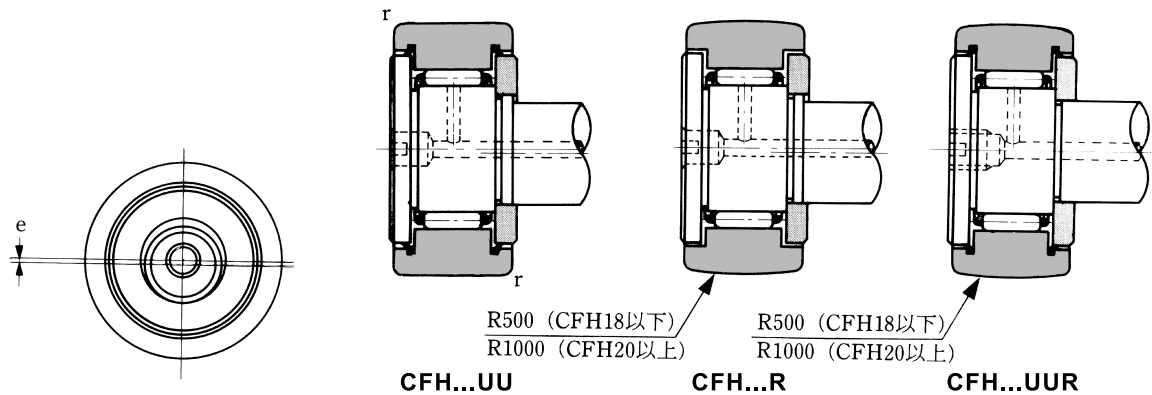

主要寸法(mm)						重量	基本定格荷重		負荷容量 Kgf	極限速率 rpm
B ₁	全長 L	d ₁	l	偏心量 e	r	grf	C kgf	Co kgf		
12	28	4	9	0.25	0.5	18.5	330	240	310 90	25000
12	32	4	11	0.25	0.5	28.5	390	300	370 120	20000
13	36	4	13	0.3	1	45	430	370	430 140	17000
13	36	4	13	0.3	1	60	430	370	500 180	17000
15	40	6	14	0.4	1.5	95	710	620	640 210	14000
15	40	6	14	0.4	1.5	105	710	620	680 240	14000
19.5	52	6	18	0.5	1.5	170	1040	1090	1020 270	10000
21.5	58	6	20	0.6	1.5	250	1410	1690	1320 320	8500
25.5	66	8	22	0.7	1.5	460	1940	2350	2110 700	7000
25.5	66	8	22	0.7	1.5	385	1940	2350	1910 610	7000
30.5	80	8	25	0.8	1.5	815	2600	3050	3120 900	6500
30.5	80	8	25	0.8	1.5	1140	2600	3050	3620 1110	6500
37	100	8	32	1.0	2	1870	3470	5350	4800 1280	5000
37	100	8	32	1.0	2	2030	3470	5350	5100 1390	5000
37	100	8	32	1.0	2	2220	3470	5350	5400 1490	5000

JOTA BEARING



久大軸承有限公司

<https://iskbearing.com/>

TEL : +886-3-325-0202

E-mail : iskbearing@jota-bearing.com.tw

Address : NO.65, Ln.1434, ChunRi RD.,
33051 Taoyuan, Taiwan, R.O.C

